

1.0 Features

- Operates in High Noise Conditions
- $\geq 36\text{dB}$ Signal Input Range
- High Sensitivity
- Low Power
- Adjustable Bandwidth
- Adjustable Frequency
- Wide Voltage Range (2.7V to 5.5V)
- Single and Multitone System Applications

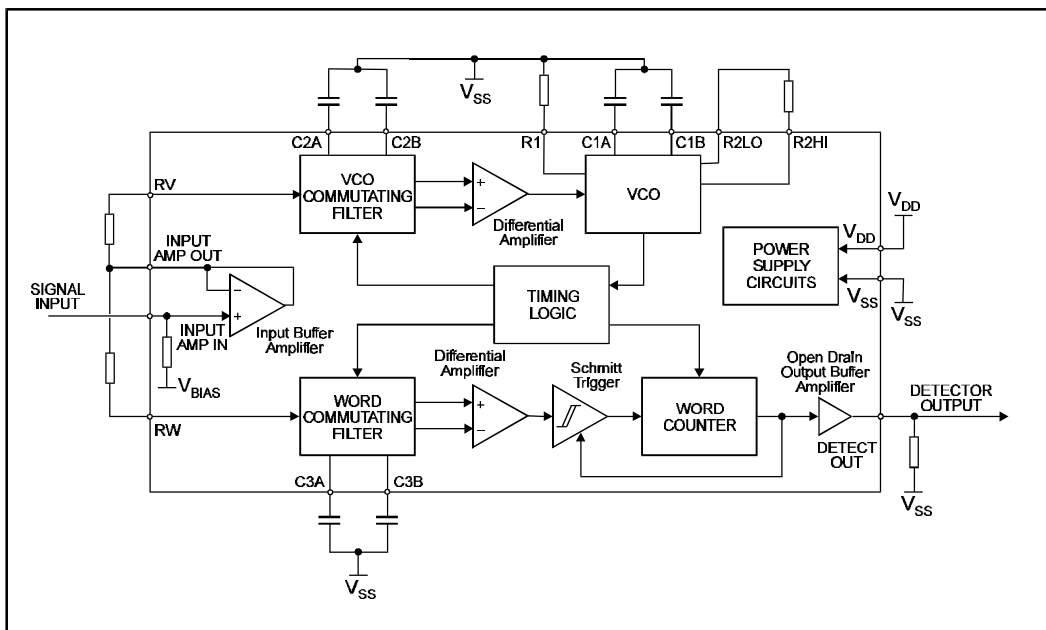

1.1 Brief Description

The FX105A is a monolithic CMOS tone operated switch, designed for tone decoding in single and multitone signalling systems. The FX105A uses decoding techniques which allow a tone to be recognised in the presence of high noise levels or strong adjacent signals. Detection centre frequency and bandwidth can each be independently adjusted. The design is immune to high levels of harmonic and sub-harmonic interference. Excellent noise immunity and constant bandwidth are maintained over a wide range of input signal levels.

CONTENTS

| <u>Section</u> | <u>Page</u> |
|--|-------------|
| 1.0 Features | 1 |
| 1.1 Brief Description..... | 1 |
| 1.2 Block Diagram | 3 |
| 1.3 Signal List..... | 4 |
| 1.4 External Components..... | 5 |
| 1.5 General Description..... | 6 |
| 1.6 Application Notes | 7 |
| 1.6.1 General | 7 |
| 1.6.2 Method for Calculating External Component Values..... | 7 |
| 1.6.3 Replacement for FX105..... | 11 |
| 1.7 Performance Specification..... | 12 |
| 1.7.1 Electrical Performance..... | 12 |
| 1.7.2 Packaging..... | 14 |

1.2 Block Diagram

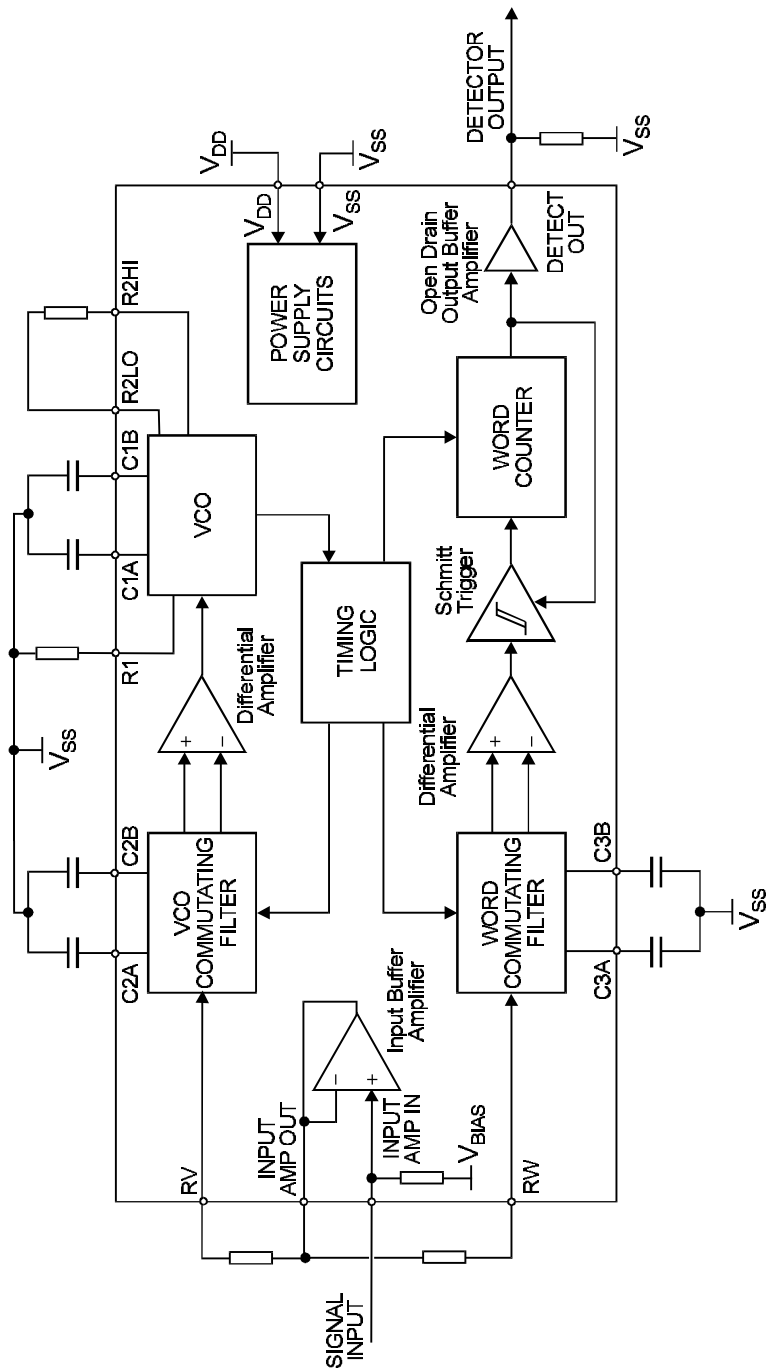

Figure 1 Block Diagram

1.3 Signal List

| Package D4/P3 | | Signal | | Description |
|---------------|---------------|--------|--|---|
| Pin No. | Name | Type | | |
| 1 | INPUT AMP IN | I/P | | AC couple to this input of the input buffer amplifier. |
| 2 | INPUT AMP OUT | O/P | | The input buffer amplifier output. |
| 3 | RW | I/P | | The input to the Detect/Word filter. |
| 4 | RV | I/P | | The input to the VCO loop filter. |
| 5 | C3A | O/P | | Word filter capacitor pin A. |
| 6 | C3B | O/P | | Word filter capacitor pin B. |
| 7 | C2A | O/P | | VCO Loop filter capacitor pin A. |
| 8 | C2B | O/P | | VCO Loop filter capacitor pin B. |
| 9 | DETECT OUT | O/P | | Open drain CMOS output, active on detect. Note that a load resistor to V_{SS} is required. |
| 10 | V_{SS} | Power | | Ground. |
| 11 | R2HI | I/P | | Bandwidth control resistor pin A. |
| 12 | R2LO | I/P | | Bandwidth control resistor pin B. |
| 13 | C1B | O/P | | VCO capacitor B. |
| 14 | C1A | O/P | | VCO capacitor A. |
| 15 | R1 | I/P | | VCO discharge resistor. When potentiometer tuning is required, a series resistor is recommended to prevent possible shorting to ground. |
| 16 | V_{DD} | Power | | Power supply. |

Notes: I/P = Input
O/P = Output

1.4 External Components

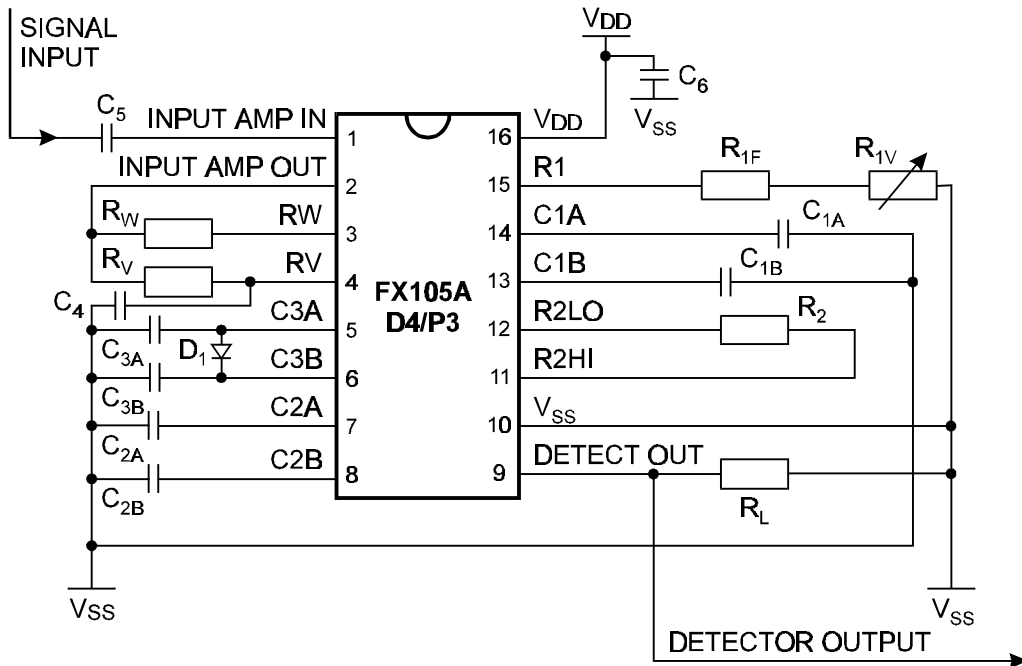

| | | | |
|-----------------|-----------------|-----------------|------------------|
| C _{1A} | See section 1.6 | R _{1F} | See section 1.6 |
| C _{1B} | See section 1.6 | R _{1V} | See section 1.6 |
| C _{2A} | See section 1.6 | R ₂ | See section 1.6 |
| C _{2B} | See section 1.6 | R _L | 20kohm ±20% |
| C _{3A} | See section 1.6 | R _V | See section 1.6 |
| C _{3B} | See section 1.6 | R _W | See section 1.6 |
| C ₄ | See section 1.6 | D ₁ | IN914 or similar |
| C ₅ | 0.27μF ±20% | | |
| C ₆ | 0.1μF ±20% | | |

- Notes:**
1. For improved performance C₄ may be chosen to provide 30° phase shift at the VCO loop filter input.
 2. For compatibility with the FX105P; capacitors (C₁ ... C₄) may be connected to V_{DD} instead of V_{SS}.
 3. For improved de-response time, a diode (D₁) may be added.
 4. Any value load resistance (R_L) may be used, providing the maximum load current does not exceed the value given in section 1.7.1

Figure 2 Recommended External Components

1.5 General Description

The input signal to the FX105A is ac coupled to the buffer amplifier input, which is internally biased at 50% of supply voltage. The signal appears at the output of the buffer amplifier as an ac voltage superimposed on the dc bias level. The signal is then coupled via R_V and R_W to the voltage controlled oscillator (VCO) and word sampling switches, which cyclically connect C_2 and C_3 into the circuit to form four sample-and-hold RC circuit integrators. See Figure 3.

With no input signal level, each capacitor charges to the dc bias level so differential voltages are zero. When an input signal is applied each capacitor receives an additional charge. This charge is determined by the integrated average of the signal waveform during the time the capacitor is switched into the circuit.

Figure 3 shows the operating sequence of the VCO sampling switches and their relationship to a locked-on in-band signal. C_{2A} and C_{2B} should not receive any additional charge since they always sample the input as it crosses the dc bias level. Should the signal not be locked to the VCO, a positive or negative charge voltage will appear on C_{2A} or C_{2B} . This voltage, when differentially amplified, is applied to the VCO as an error correcting signal to enable the VCO to "lock."

Figure 3 also shows the operating sequence of the "Word" sampling switches and their relationship to a locked-on in-band signal. As the figure shows, the charge applied to C_{3A} should always be positive, and the charge applied to C_{3B} should always be negative (with respect to the common bias level).

These capacitor potentials are differentially amplified and applied to a dc comparator, which switches at a pre-determined threshold voltage V_{TH} (known as the word filter sensitivity). The comparator output is a logic signal used to control a counter. This counter switches the FX105A output ON when the comparator output is maintained in the "Word present" state for a minimum number of consecutive signal samples. The activated output switch reduces the comparator threshold by 50%, introducing threshold hysteresis. Output chatter with marginal input signal amplitudes is thereby minimised.

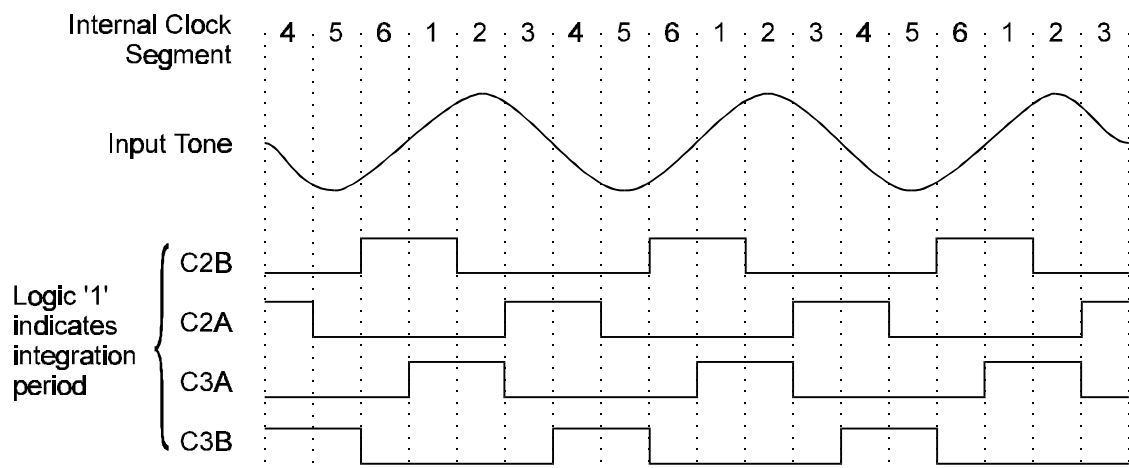

Figure 3 Sampling Clocks of Commutating Filters

1.6 Application Notes

1.6.1 General

The external components shown in Figure 2 are used to adjust the various performance parameters of the FX105A. The signal-to-noise performance, response time and signal bandwidth are all interrelated factors which should be optimised to meet the requirements of the application.

By selecting component values in accordance with the following formulae, optimum circuit performance is obtained for any given application.

First define the following application parameters:

- The input frequency to be detected (f_0). The free running frequency of the VCO is set to 6 times this frequency by observing the output across C_1 or R_1 . (The frequency observed at pin 15 (R_1) is $6 \times f_0$ and the frequency observed at pins 13 or 14 (C_{1A} or C_{1B}) is $3 \times f_0$).
- The FX105A Minimum mUsable Bandwidth (MUBW). This is obtained by taking into account the worst case tolerances Δf_0 of the input frequency and the variations in the FX105A VCO frequency due to supply voltage ΔV_{DD} and temperature ΔTEMP variation of the FX105A and its supporting components.
- The maximum permissible FX105A response time.
- The minimum input signal amplitude. (This must be larger than the threshold voltage, V_{TH}).
- The maximum input signal amplitude.

Using this information the appropriate component values can be calculated, and the signal-to-noise performance can be read from a chart. Do not add large safety margins for response time and minimum signal amplitude: reasonable margins are already included in the formulae. Excessive margins may result in reduced noise immunity.

1.6.2 Method for Calculating External Component Values

The example on the following pages demonstrates the calculation of component values for any given application. For the purpose of this example, the values below are used:

- $f_0 = 2800\text{Hz}$
- $\Delta \text{TEMP} = 100^\circ\text{C}$, $\Delta V_{DD} = 1\text{V}$, $\Delta f_0 = 0.5\%$
- Maximum allowed response time $T_{ON} = 50\text{msec}$
- Minimum input signal amplitude $V_{IN\text{MIN}} = 200\text{mVrms}$
- Maximum input signal amplitude $V_{IN\text{MAX}} = 400\text{mVrms}$

1.6.2.1 Calculate R_1C_1 ($C_{1A} = C_{1B}$)

The components R_1 , C_{1A} and C_{1B} set the free running frequency of the VCO and therefore the f_0 of the FX105A. As shown below, the frequency of 2800Hz corresponds to a capacitor value of 220pF and a resistor value of 385 Ω . This resistance can be achieved with a 330 Ω fixed resistor and a 100k Ω potentiometer. R_1 should lie in the range 100 Ω to 680k Ω .

$$R_1C_{1A} = 1/[2Kf_0] = 1/(2 \times 2.1 \times 2800) = 85\mu\text{sec}$$

where K is a constant $\approx 2.1 \pm 5\%$.

Note that the values of C_{1A} and C_{1B} need to include the stray capacitance attributable to the package style and printed circuit board layout. A typical value of 6.6pF per pin should be assumed.

$$\text{If } C_{1A} = C_{1B} = 233.2\text{pF, then } R_1 \gg 364\text{kohm}$$

1.6.2.2 Calculate Minimum Usable Bandwidth (%)

Minimum Usable Bandwidth (MUBW) is the TOTAL (%) bandwidth required for the following:

- (a) Input signal frequency tolerance (Δf_0)
- (b) FX105A VCO temperature coefficient ($T_C = -100\text{ppm}/^\circ\text{C}$)
- (c) FX105A VCO supply voltage coefficient ($V_C = 2330\text{ppm}/\text{V}$)

Add (a), (b) and (c) and express as TOTAL (%) bandwidth, **not** as a \pm (%) value.

$$\text{MUBW} = \Delta f_0 + |T_C|D\text{TEMP} + V_C DV_{DD}$$

$$\text{MUBW} = 0.5 + 0.01 \times 100 + 0.233 \times 1 \gg 2\%$$

1.6.2.3 Calculate the Recommended Operating Bandwidth

Note again that this is the TOTAL (%) bandwidth:

$$\text{BW} = \frac{1}{2} [10 + \text{MUBW}] = \frac{1}{2} (10 + 2) = 6\%$$

1.6.2.4 Select R_2 for Operating BW

$$R_2 = 4.8 \text{ BW} / [10.35 - \text{BW}] = 4.8 \times 6 / (10.35 - 6) \gg 6.8\text{k}\Omega$$

The exact bandwidth given by any value of R_2 will vary slightly. In applications where an exact bandwidth is required, R_2 should be a variable resistor to permit adjustment.

1.6.2.5 Calculate $R_V C_{2A}$ ($C_{2A} = C_{2B}$) Use nearest preferred values

$$R_V C_{2A} \gg 100 / [3 f_0 \text{ BW}] \gg 100 / (3 \times 2800 \times 6) \gg 2\text{msec}$$

Therefore $R_V \gg 200\text{k}\Omega$ for $C_{2A} = C_{2B} = 10\text{nF}$

1.6.2.6 Define the Maximum Allowed Response Time

The maximum response time (T_{ON}) is the sum of the VCO lock time (T_{LOCK}) and the Word integration time (T_{WORD}). The FX105A's T_{ON} must not exceed the maximum time allowed for the application, but a value lying near the maximum gives the best S/N performance.

- (a) Calculate T_{LOCK}

$$T_{LOCK} = 150 / [f_0 \text{ BW}] = 150 / (2800 \times 6) \gg 9\text{msec}$$

Note: T_{LOCK} may vary from near zero to the value given, causing corresponding variations in actual T_{ON} .

- (b) Calculate Maximum Allowable T_{WORD}

$$T_{WORD} = T_{ON\text{MAX}} - T_{LOCK} = 50 - 9 = 41\text{msec}$$

Note: Since the maximum allowed response time (T_{ON}) is 50msec, a maximum Word integration time of 41msec is available.

1.6.2.7 Calculate $R_W C_{3A}$ ($C_{3A} = C_{3B}$) Use nearest preferred values.

$$R_W C_{3A} \gg T_{\text{WORD}} / [-3 \ln (1 - V_{\text{TH}} / V_{\text{IN}_{\text{MIN}}})] \quad \text{where } V_{\text{TH}} \text{ is the word filter sensitivity, see Section 1.7.1}$$

A signal amplitude of 200mV and a resistor value R_W of 465k Ω with a 220nF capacitor for C_{3A} and C_{3B} will yield a T_{WORD} time of 41msec. This in turn yields a response time of 9msec + 41msec = 50msec.

1.6.2.8 Calculate the Maximum De-response Time

$$T_{\text{OFF}} \gg -3 R_W C_{3A} \ln (V_{\text{TH}} / V_{\text{IN}_{\text{MAX}}}) \quad \text{where } V_{\text{TH}} \text{ is the word filter sensitivity, see Section 1.7.1}$$

For improved de-response time, a diode (1N914 or similar) can be placed between pins 5 and 6, as shown in Figure 2. The formula and figure below show the approximate time the FX105A will take to turn off after an in-band signal has been removed. The effect of this diode is to greatly reduce the turn-off time with signal input amplitudes greater than 300mV_{rms}. Figure 4 is for $V_{\text{DD}} = 5\text{V}$; for lower V_{DD} then K_{DT} increases.

$$T_{\text{OFF}} \gg K_{\text{DT}} R_W C_{3A}$$

So for a maximum signal amplitude of 400mV, a resistor value R_W of 465k Ω with a 220nF capacitor for C_{3A} and C_{3B} and a diode between pins 5 and 6, a de-response time of $\approx 363\text{msec}$ is obtained.

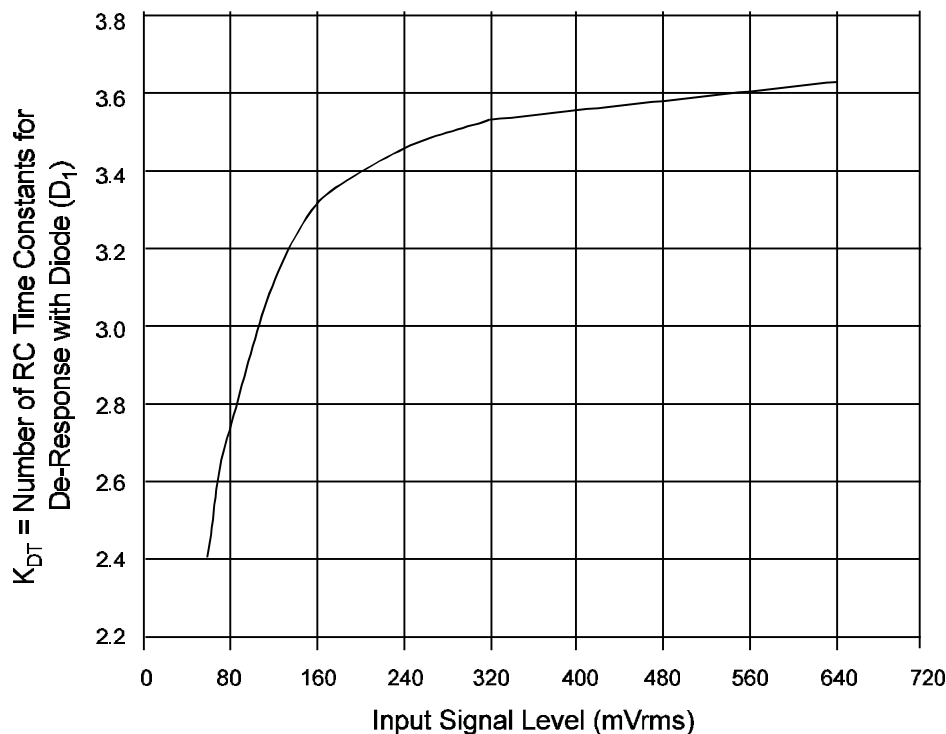

Figure 4 K_{DT} Factor for T_{OFF} vs. Signal Input Amplitude

1.6.2.9 Calculate Signal to Noise Performance

Worst-case S/N calculations depend on calculation of a value "M" using the formula shown below:

$$M = R_W C_{3A} / [3 R_V C_{2A}]$$

substituting our example values,

$$M = 465 \times 0.22 / (3 \times 200 \times 0.01) = 17.05$$

By substituting this value for M in Figure 5 the minimum required S/N of an in band tone with respect to an adjacent interfering tone can be found. This has to be increased if the required tone amplitude is close to the word filter sensitivity V_{TH} .

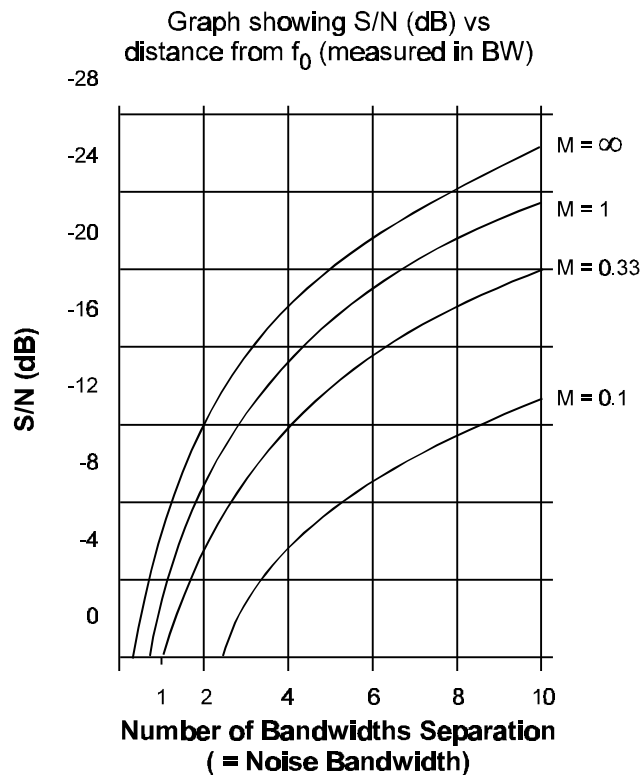

Figure 5 S/N vs. BW Separation

The following formula expresses the reduction in noise immunity as the input signal approaches the word filter sensitivity V_{TH} .

$$\text{required S/N} = 20 \log (V_{IN} / [V_{IN} - V_{TH}]) + S/N_{\text{Figure 5}}$$

If this S/N is better than required for the application, $R_W C_{3A}$ can be reduced, or the operating bandwidth can be increased to obtain a faster tone detection time.

If the S/N performance is not adequate, the operating bandwidth can be reduced toward the MUBW, or $R_W C_{3A}$ can be increased to improve S/N performance at the expense of a slower response time.

1.6.2.10 Calculation of PLL Filter Phase Shift

Capacitor C_4 is used to phase shift the input to the VCO commutating filter by 30° , thus shifting the sampling clocks by the same amount. This enables the "Word" sampling filter to sample and integrate at the maxima and minima of the input tone.

$$C_4 = \tan(30^\circ) / [2\pi f_0 R_V] \gg 0.092 / [f_0 R_V] \gg 164\text{pF}$$

1.6.3 Replacement for FX105

Figure 6 depicts the circuit changes required to replace a FX105 with a FX105A device. A 5V zener diode and a resistor can be used to generate a 5V supply voltage from an existing 12V supply. If the Detect Output needs to pull up beyond the 5V supply, a transistor amplifier following the output can be used.

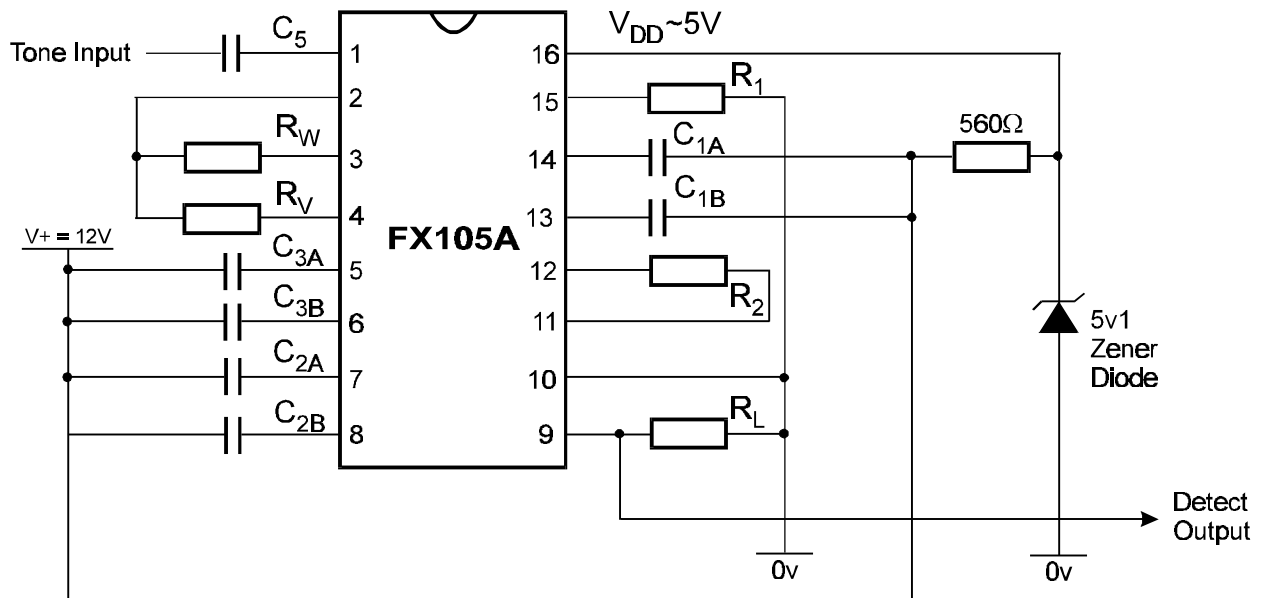

Figure 6 Circuit changes for 12V to 5V conversion

1.7 Performance Specification

1.7.1 Electrical Performance

Absolute Maximum Ratings

Exceeding these maximum ratings can result in damage to the device.

| | Min. | Max. | Units |
|---|------|----------------|-------|
| Supply ($V_{DD} - V_{SS}$) | -0.3 | 7.0 | V |
| Voltage on any pin to V_{SS} | -0.3 | $V_{DD} + 0.3$ | V |
| Current into or out of V_{DD} and V_{SS} pins | -30 | +30 | mA |
| Current into or out of any other pin | -20 | +20 | mA |
| Maximum Output Switch Load Current | | +10 | mA |

| P3/D4 Package | Min. | Max. | Units |
|---|------|------|------------------------|
| Total Allowable Power Dissipation at $T_{amb} = 25^{\circ}\text{C}$ | | 800 | mW |
| ... Derating | | 13 | mW/ $^{\circ}\text{C}$ |
| Storage Temperature | -55 | +125 | $^{\circ}\text{C}$ |
| Operating Temperature | -40 | +85 | $^{\circ}\text{C}$ |

Operating Limits

Correct operation of the device outside these limits is not implied.

| | Notes | Min. | Max. | Units |
|------------------------------|-------|------|------|--------------------|
| Supply ($V_{DD} - V_{SS}$) | | 2.7 | 5.5 | V |
| Operating Temperature | | -40 | +85 | $^{\circ}\text{C}$ |

Operating Characteristics

For the following conditions unless otherwise specified:

$$V_{DD} = 3.0V \text{ to } 5.0V, T_{amb} = -40^{\circ}C \text{ to } +85^{\circ}C, \text{ Load resistance on decoder output pin} = 20k\Omega$$

| | Notes | Min. | Typ. | Max. | Units |
|-----------------------------------|-------|------|------|---------|------------------|
| Static Parameters | | | | | |
| I_{DD} | 2 | - | 0.9 | 3.0 | mA |
| Amplifier Input Impedance | | - | 200 | - | k Ω |
| Digital Output Impedance | | - | 500 | - | Ω |
| Analogue Output Impedance | | - | 1000 | - | Ω |
| Dynamic Parameters | | | | | |
| Input Signal | | | | | |
| Amplitude | 2 | - | - | 1.0 | Vrms |
| Frequency | | 40 | - | 20,000 | Hz |
| Response Threshold | 1,2 | - | 30 | - | mVrms |
| Deresponse Threshold | 1,2 | - | 10 | - | mVrms |
| BW Range | 4 | 5.6 | - | 10 | % f_0 |
| Signal to Noise Performance | | -6 | -9 | - | dB |
| ($f_0/2$) Subharmonic Rejection | | - | 30 | - | dB |
| ($5 f_0$) Harmonic Rejection | | - | 20 | - | dB |
| VCO | | | | | |
| Frequency | 3 | 240 | - | 120,000 | Hz |
| Frequency Stability (T_C) | | - | -100 | - | ppm/ $^{\circ}C$ |
| Frequency Stability (V_C) | | - | 2330 | - | ppm/V |
| Amplifier | | | | | |
| Open Loop Gain | | - | 60 | - | dB |
| Gain Bandwidth Product | | - | 1.0 | - | MHz |
| Closed Loop Gain | | - | 0 | - | dB |
| Word Commutating Filter | | | | | |
| Sensitivity (V_{TH}) | 2 | - | 25.0 | - | mVrms |

- Notes:**
1. With diode (D_1) fitted.
 2. For $V_{DD} = 5V$. Multiply by $V_{DD}/5V$ for other supply values.
 3. Observing pins 13, 14 or 15 (D4/P3 package) will cause a frequency shift due to additional loading. If tuning the centre frequency by observing the VCO, design in a buffer amplifier between pin 15 and the probe/calibration point and tune with no input signal. Otherwise, tune by observing the detect output band edges while sweeping the input signal. The frequency at pin 15 is $6xf_0$, while at pins 13 and 14 the frequency is $3xf_0$.
 4. Adjust according to equation for R_2 in Section 1.6.2.

1.7.2 Packaging

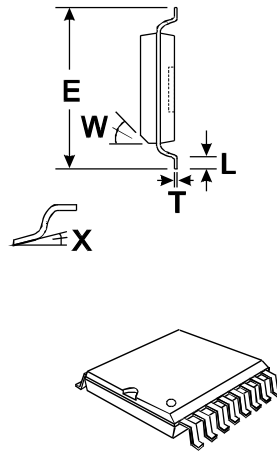
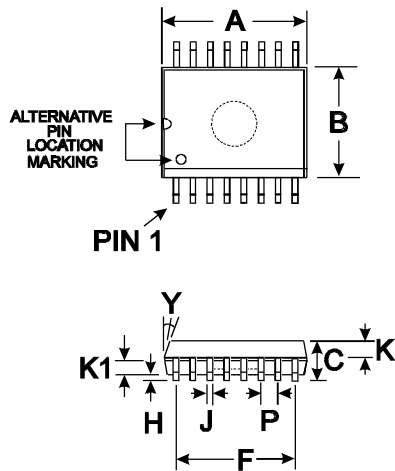

DIM. MIN. TYP. MAX.

| | | | |
|-----|---------------|--------------|---------------|
| * A | 0.395 (10.03) | | 0.413 (10.49) |
| * B | 0.286 (7.26) | | 0.299 (7.59) |
| C | 0.093 (2.36) | | 0.105 (2.67) |
| E | 0.390 (9.90) | | 0.419 (10.64) |
| F | | 0.350 (8.89) | |
| H | 0.003 (0.08) | | 0.020 (0.51) |
| J | 0.013 (0.33) | | 0.020 (0.51) |
| K | | 0.041 (1.04) | |
| K1 | | 0.041 (1.04) | |
| L | 0.016 (0.41) | | 0.050 (1.27) |
| P | | 0.050 (1.27) | |
| T | 0.009 (0.23) | | 0.0125 (0.32) |
| W | | 45° | |
| X | 0° | | 10° |
| Y | | 7° | |

NOTE :

* A & B are reference datum's and do not include mold deflash or protrusions.

All dimensions in inches (mm.)
Angles are in degrees

Figure 7 - SOIC Mechanical Outline: Order as part no. FX105AD4

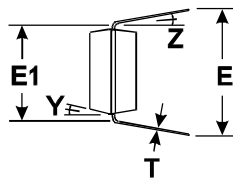
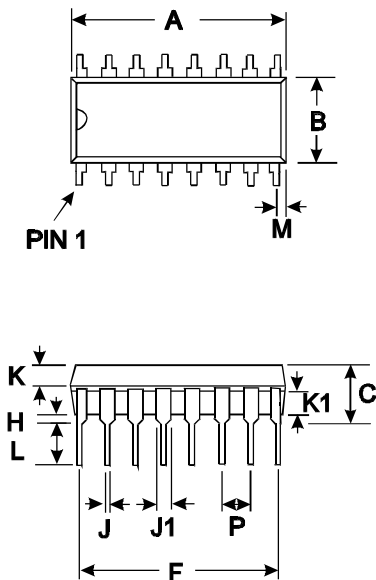

DIM. MIN. TYP. MAX.

| | | | |
|-----|---------------|--------------|---------------|
| * A | 0.740 (18.80) | | 0.810 (20.57) |
| * B | 0.240 (6.10) | | 0.262 (6.65) |
| C | 0.135 (3.43) | | 0.200 (5.08) |
| E | 0.300 (7.62) | | 0.390 (9.91) |
| E1 | 0.290 (7.37) | | 0.325 (8.26) |
| F | | 0.70 (17.78) | |
| H | 0.015 (0.38) | | 0.040 (1.02) |
| J | 0.015 (0.38) | | 0.023 (0.58) |
| J1 | 0.040 (1.02) | | 0.065 (1.65) |
| K | 0.056 (1.42) | | 0.064 (1.63) |
| K1 | 0.056 (1.42) | | 0.064 (1.63) |
| L | 0.121 (3.07) | | 0.150 (3.81) |
| M | | 0.028 (0.71) | |
| P | | 0.100 (2.54) | |
| T | 0.008 (0.20) | | 0.015 (0.38) |
| Y | | 7° | |
| Z | | 5° | |

NOTE :

* A & B are reference datum's and do not include mold deflash or protrusions.

All dimensions in inches (mm.)
Angles are in degrees

Figure 8 - DIL Mechanical Outline: Order as part no. FX105AP3

Handling precautions: This product includes input protection, however, precautions should be taken to prevent device damage from electro-static discharge. CML does not assume any responsibility for the use of any circuitry described. No IPR or circuit patent licences are implied. CML reserves the right at any time without notice to change the said circuitry and this product specification. CML has a policy of testing every product shipped using calibrated test equipment to ensure compliance with this product specification. Specific testing of all circuit parameters is not necessarily performed.



**Oval Park - LANGFORD
MALDON - ESSEX
CM9 6WG - ENGLAND**

**Telephone: +44 (0)1621 875500
Telefax: +44 (0)1621 875600
e-mail: sales@cmlmicro.co.uk
<http://www.cmlmicro.co.uk>**



CML Microcircuits

COMMUNICATION SEMICONDUCTORS

CML Product Data

In the process of creating a more global image, the three standard product semiconductor companies of CML Microsystems Plc (*Consumer Microcircuits Limited (UK)*, *MX-COM, Inc (USA)* and *CML Microcircuits (Singapore) Pte Ltd*) have undergone name changes and, whilst maintaining their separate new names (*CML Microcircuits (UK) Ltd*, *CML Microcircuits (USA) Inc* and *CML Microcircuits (Singapore) Pte Ltd*), now operate under the single title **CML Microcircuits**.

These companies are all 100% owned operating companies of the CML Microsystems Plc Group and these changes are purely changes of name and do not change any underlying legal entities and hence will have no effect on any agreements or contacts currently in force.

CML Microcircuits Product Prefix Codes

Until the latter part of 1996, the differentiator between products manufactured and sold from MXCOM, Inc. and Consumer Microcircuits Limited were denoted by the prefixes MX and FX respectively. These products use the same silicon etc. and today still carry the same prefixes. In the latter part of 1996, both companies adopted the common prefix: CMX.

This notification is relevant product information to which it is attached.

Company contact information is as below:



**CML Microcircuits
(UK) Ltd**

COMMUNICATION SEMICONDUCTORS

Oval Park, Langford, Maldon,
Essex, CM9 6WG, England
Tel: +44 (0)1621 875500
Fax: +44 (0)1621 875600
uk.sales@cmlmicro.com
www.cmlmicro.com



**CML Microcircuits
(USA) Inc.**

COMMUNICATION SEMICONDUCTORS

4800 Bethania Station Road,
Winston-Salem, NC 27105, USA
Tel: +1 336 744 5050,
0800 638 5577
Fax: +1 336 744 5054
us.sales@cmlmicro.com
www.cmlmicro.com



**CML Microcircuits
(Singapore) Pte Ltd**

COMMUNICATION SEMICONDUCTORS

No 2 Kallang Pudding Road, 09-05/
06 Mactech Industrial Building,
Singapore 349307
Tel: +65 7450426
Fax: +65 7452917
sg.sales@cmlmicro.com
www.cmlmicro.com